

CHAPTER 28

Wall Paneling

Section 28.1 Sheet Paneling

Section 28.2 Board Paneling

Chapter Objectives

After completing this chapter, you will be able to:

- **Identify** the three basic types of paneling.
- **Explain** the difference between full-height paneling and wainscoting.
- **Explain** the proper methods for storing and conditioning paneling.
- **Demonstrate** how to install sheet paneling.
- **Differentiate** between horizontal paneling and vertical paneling.
- **Estimate** the amount of sheet paneling required for a room.



Discuss the Photo

Paneling Raised paneling is made out of solid wood. *Why might raised paneling be simulated?*



Writing Activity: Identify Purpose

Before you read, you should decide on your purpose for writing. Is it to inform, persuade, inquire, or describe? Write a one-page e-mail or letter to a remodeling supply store asking them what types of wall paneling products they sell most frequently. State the purpose of your letter.



Before You Read Preview

The texture and versatility of wood paneling make it popular as an indoor wall finish. Wood paneling can dramatically change the look of a room and can be installed over drywall, plaster, and masonry surfaces. Choose a content vocabulary or academic vocabulary word that is new to you. When you find it in the text, write down the definition.

Content Vocabulary

- full-height paneling
- sticker
- board paneling
- wainscoting
- box extender
- blind nailing

Academic Vocabulary

You will find these words in your reading and on your tests. Use the academic vocabulary glossary to look up their definitions if necessary.

- randomly
- contraction
- simulated

Graphic Organizer

As you read, use a chart like the one shown to organize information about content vocabulary words and their definitions, adding rows as needed.

Content Vocabulary	Definition
full-height paneling	paneling that runs from floor to ceiling

Go to glencoe.com for this book's OLC for a downloadable version of this graphic organizer.

Academic Standards



Mathematics

Measurement: Apply appropriate techniques, tools, and formulas to determine measurements (NCTM)

Problem Solving: Apply and adapt a variety of appropriate strategies to solve problems (NCTM)



English Language Arts

Use written language to communicate effectively (NCTE 4)

Use language to accomplish individual purposes (NCTE 12)



Science

Earth and Space Science: Energy in the earth system (NSES)

Industry Standards

Wall Sheet Paneling Installation

NCTE National Council of Teachers of English
NCTM National Council of Teachers of Mathematics

NSES National Science Education Standards

Sheet Paneling

Sheet Paneling Basics

What trades might be affected by the installation of paneling?

Paneling made of engineered wood or solid wood offers an alternative to painted walls. It is typically applied over an existing wall surface such as drywall, so installation occurs near the end of home construction.

Paneling that runs from floor to ceiling is referred to as **full-height paneling**. Paneling that runs partway up the wall from the floor is called **wainscoting**. It is usually about 32" high.

Sheet paneling, such as the paneling shown in **Figure 28-1**, is the most common type of wall paneling. Most sheet-panel products are made of plywood, hardboard, or medium-density fiberboard (MDF). MDF paneling is



Figure 28-1 Sheet Paneling

Room Changer The installation of full-height wall paneling covers walls quickly and can have a dramatic effect on a room.



JOB SAFETY

MOVING SHEET PANELING Sheet paneling is unwieldy, and even thin sheets can be awkward to handle. Never move more than one sheet of paneling at a time unless you have help. When lifting panels, lift with your knees. To do this, lift while keeping your back straight. When carrying panels, avoid any twisting motion that may strain your lower back.

Go to glencoe.com for this book's OLC for more on job safety.

sometimes referred to as *panelboard*. Sheet paneling is most commonly found in 4×8 sheets, but 4×3, 4×6, and 4×10 sheets are also available. Thicknesses include $\frac{5}{32}$ ", $\frac{3}{16}$ ", $\frac{1}{4}$ ", $\frac{3}{8}$ ", $\frac{1}{2}$ ", $\frac{5}{8}$ ", and $\frac{3}{4}$ ". The edges along the panel's length may be square or rabbeted. The edges along its width are square.

Sheet paneling is typically supplied prefinished. It is available in many textures and patterns, including saw-textured, relief-grain, embossed, and grooved. Plywood and medium-density fiberboard (MDF) paneling are available with a wide variety of surface veneers, including domestic and tropical hardwoods. Some paneling is finished so that it appears to be very old, such as the paneling shown in **Figure 28-2**.

Suitable Locations

Sheet paneling made of plywood shares characteristics with other plywood products, including strength and stability (see Section 13.3). MDF panels can be damaged by moisture and high humidity. They should not be used in unheated rooms or in humid areas such as basements and



Figure 28-2 Antiqued Paneling
The New Old The indentations that suggest age can be felt as well as seen in this antiqued plywood paneling used as an accent wall.

bathrooms. Panels that are $\frac{5}{32}$ " thick or less should always be installed over a backing that will not catch fire, such as drywall. Thicker panels can be attached directly to studs if local building codes permit the practice. Panels $\frac{5}{32}$ " thick should never be placed over masonry. Other thicknesses can be installed over masonry according to the manufacturer's instructions.

Storage and Conditioning

Always store paneling indoors. Stack it on the floor, using stickers to separate the sheets. A **sticker** is a long, slender piece of scrap wood that separates layers of wood products and allows air circulation between them. Stacking panels in this way prevents them from warping. If you must store sheet paneling on edge, make sure that the panels rest on a long edge. Place stickers beneath the panels to raise them off the floor.

Paneling must be conditioned before installation. *Conditioning* means that the paneling has been in the room in which it will be used for a certain period of time. This allows the paneling to become accustomed to the temperature and humidity of the room. Condition sheet paneling for at least 48 hours.

Installing Sheet Paneling

What is mastic?

The methods for installing most sheet paneling products are similar. It is always wise, however, to consult the manufacturer's instructions first for any special precautions. The following instructions cover the installation of plywood paneling.

Local codes may allow the installation of thick paneling directly to studs. However, it is often recommended that any thickness of sheet paneling be applied over drywall. Drywall provides a fire-resistant base and solid support. Sheet paneling is secured to the wall with finishing nails, brads, or a combination of nails and panel mastic. *Mastic* is a thick adhesive that can be applied with a notched trowel or with a caulking gun.

Wall Preparation

Drywall must be taped and sanded before paneling is installed. Otherwise, irregularities in the surface will make installation difficult. Nail or screw dimples should be filled and the drywall should be primed.

Remodeling Paneling is often installed in remodeling projects. Remove all plates around wall switches and receptacles and save them for reuse. Though thin sheet paneling can be installed without removing existing trim, this method requires great precision. It is sometimes easier in the long run to remove window and door casings.

Builder's Tip

REMOVING MOLDING AND TRIM When removing trim that must be reused, pry it carefully away from the wall. Pull out any remaining nails through the backside of the trim, using nippers. This prevents the head of the nail from splintering the face of the trim as it exits. You can fill in the nail holes with wood putty.

JOB SAFETY

AVOIDING KICKBACK Sheet paneling is often cut using a table saw. However, thin panels are very flexible and may bend as they are being cut. This can cause the panel to pinch the saw blade, leading to a very dangerous condition called *kickback*. To prevent kickback, support thin paneling adequately across its width during the cutting operation. It must also be supported as it leaves the saw. For more on preventing kickback, see Section 5.2.

Go to glencoe.com for this book's OLC for more on job safety.

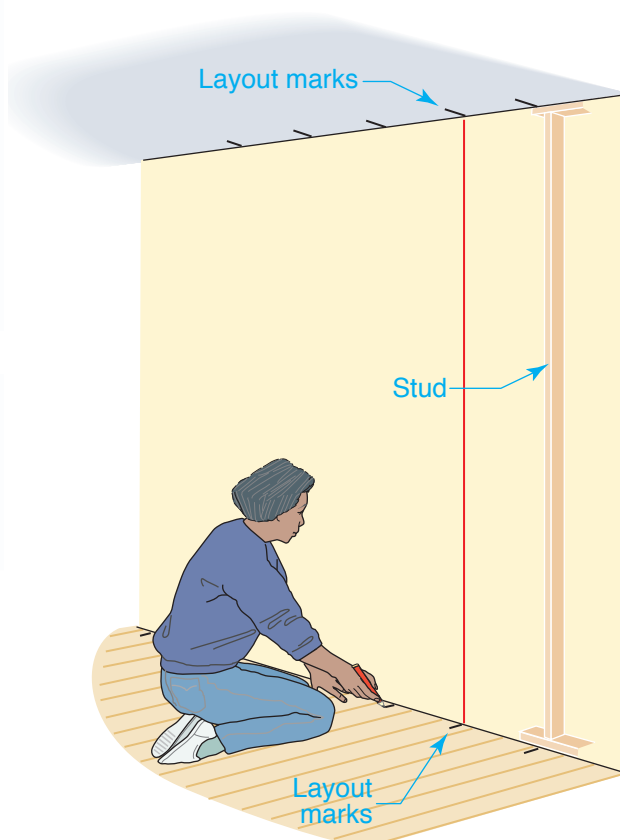

Figure 28-3 Wall Preparation
Nailing Guides Mark the locations of wall studs at the ceiling and at the floor.

It is nearly always best to remove baseboard trim. Trim can be reinstalled unless it is damaged during removal.

New Construction Walls must be clean and flat. Sand or scrape down high spots. Locate the position of studs in the existing wall. They are generally on 16" centers. Lightly mark the stud center locations on the floor and ceiling to serve as a guide when nailing each panel into position, as shown in **Figure 28-3**.

Reading Check

Explain Why is it best to install paneling over a drywall surface?

Planning the Installation

Panels are generally applied with the long dimension running vertically. Stand the panels on edge side by side around the room. Arrange them by natural color variations into a pleasing pattern.

For most rooms, it is practical to start paneling from one inside corner and then work around the room in only one direction. After you have established their order, number each panel on the back and set it aside.

If the panel has vertical grooves, their locations may appear to be **randomly** spaced. However, they will usually be spaced to align with standard 16" stud spacing, as shown in **Figure 28-4**. By nailing the panel through the grooves, the nail

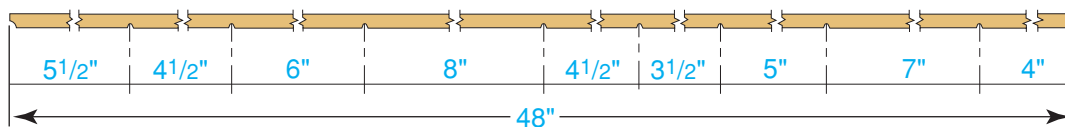

Figure 28-4 Groove Spacing
Measuring System When the dimensions are added together, the grooves fall on 16" and 24" centers. In this way, the grooves can be used to identify the location of studs.

heads are hidden. However, for this spacing arrangement to work, the first panel in a wall must be set into place carefully. It must be plumb and the grooves must be aligned with the layout marks on the floor and ceiling.

Cutting Paneling

When cutting panels with a crosscut handsaw or table saw, place the face side (the “good” side) of the panel up. This reduces splintering. If you are using a circular saw or a saber saw, cut the panel with the face side down. The best blade to use in a circular saw or a table saw is a plywood-cutting blade (see Chapter 5).

Another way to reduce splintering is to place a strip of masking tape where you will make the cut. This is particularly helpful when crosscutting paneling. When making cutouts in a panel, such as for an electrical box, another way to reduce splintering is to score the cutting line with a utility knife. Then cut the panel on the waste side of the scored line.

Installing the First Panel

Positioning and installing the first panel determines the layout of all subsequent panels. The Step-by-Step Application on page 812 shows how to install the first panel.

Installing Additional Panels

Once the first panel is secure, position the second panel to the first. The panels should not be butted tightly together. To allow for expansion, a $\frac{1}{16}$ " gap is recommended for hardboard and MDF panels. A smaller gap is recommended for plywood panels. If the first panel has been properly positioned, the edges of all the other full-width panels will also land on stud centers. This assumes that the stud spacing is uniform across the wall.

Making Cutouts

A hole must often be cut in a panel to accommodate an electrical box. It is possible to measure the distance from the floor to the box, but it is quicker and generally more accurate to use the following method.

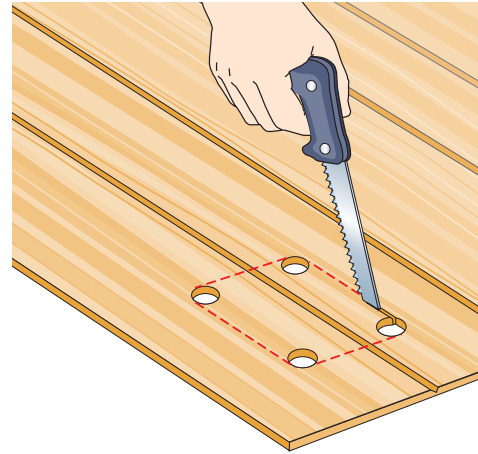

Figure 28-5 Making Cutouts

Cut Between Holes Cutting an opening for an electrical outlet box.

1. Rub carpenter’s chalk against the edges of the box. Then, hold the panel in place against it.
2. Strike the face of the panel sharply several times with the heel of your hand to transfer the box outline to the back of the panel.
3. Drill pilot holes in the corners of the marked outline. A plunge cut can also be made, eliminating the need for pilot holes (see Chapter 5).
4. Cut along the outline with a keyhole saw, as shown in **Figure 28-5**, or use a jigsaw fitted with a blade that reduces splintering. Special woodworking blades are available for this but many trim carpenters find that a blade intended for cutting metal works just as well.

Box Extenders Building codes require that the front of any electrical box should be flush with the surface of the wood paneling when the job is complete. This prevents combustible materials from being exposed to possible short circuits within the box. If the box is not flush, it should either be repositioned or fitted with a box extender. A **box extender** is a metal or plastic fitting that is screwed to the front of the outlet box, bringing it forward.

Step-by-Step Application

Positioning the First Panel Positioning and fastening are usually done together.

Step 1 Measure the height of the wall in several places. If the height is less than 8', subtract $\frac{1}{2}$ " from this dimension and cut the first 4 × 8 panel to length. This will provide $\frac{1}{4}$ " at top and bottom for expansion and contraction. If the height is greater than 8', start with a 4 × 10 panel.

Step 2 Place the panel in position in a corner and butt it to the adjacent wall. The room corners may be irregular, particularly in an older house. Make sure the panel is perfectly plumb and its outer edge is directly over the centerline of a stud. If this edge does not fall directly on the stud, trim the other side of the panel so it will.

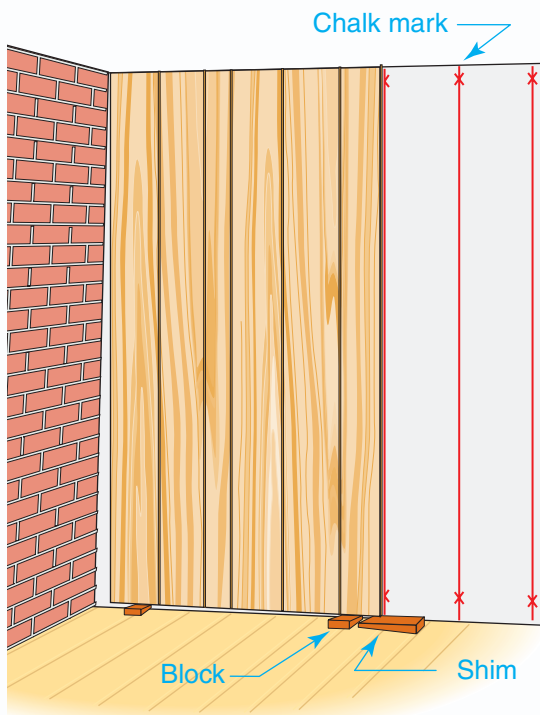

Step 3 Position the panel at the proper height by shimming it to allow for $\frac{1}{4}$ " clearance at the bottom. When the panel is set perfectly plumb and at the correct height, check for gaps between the panel and the corner. If the panel fits tightly, proceed to Step 7. If there is an irregular gap between the panel and the corner, the panel must be scribed.

Step 4 Set a compass for an amount equal to the widest gap between the panel edge and the corner. Scribe a line on the panel. To scribe the panel edge, hold the compass tip against the wall and move the compass downward. The compass should be level. The tip will follow imperfections in the wall and the pencil will record them.

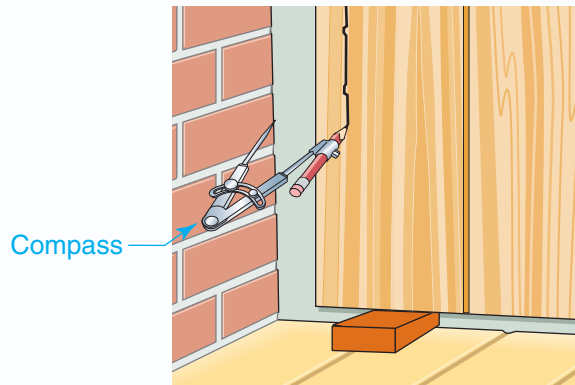

Step 5 Using a jigsaw or circular saw, cut the panel along this line so it will fit the corner.

Step 6 Set the panel back in place against the wall and again shim it to the correct height. Now it should fit the corner exactly.

Step 7 Nail the first panel to the wall. Fastening techniques will be discussed on the next page.



Go to glencoe.com for this book's OLC for additional step-by-step procedures, applications, and certification practice.

Fastening Panels

The nailing patterns for plywood paneling depend on the spacing of supports and the thickness of the panels (see **Table 28-1**).

1. Use colored ringshank nails that blend

with the wood finish. This will eliminate the need for countersinking and puttying nail holes. Space the nails every 6" along panel edges. Space them every 12" along intermediate studs.

Builder's Tip

LOCATING HIGH NAILS As work progresses, the panels should be checked for any nails that are not fully set. It is difficult to see a colored nail against the paneling surface, however. It is usually easier to find unset nails by lightly rubbing your hand over the paneling—you will feel nails you cannot see.

- When nailing is complete, check that all nails are set properly and that the paneling is tight against the wall.

Prefinished paneling may also be nailed with standard finishing nails. If this technique is used, countersink the nails slightly below the surface of the paneling. Fill the holes using a putty stick that matches the color of the paneling.

Panel adhesive may be used instead of nails, though at least a few nails are usually necessary to hold a panel in place as the adhesive cures. Be sure to follow the adhesive manufacturer's instructions. Use only a latex, water-based adhesive with MDF paneling. Solvent-based adhesives may discolor finishes on this product.

- After the panels have been properly cut and fitted, apply the adhesive to the wall surface or the back of the panel. Use a caulking gun to create a continuous $\frac{3}{16}$ " – $\frac{1}{4}$ " wide bead around the perimeter

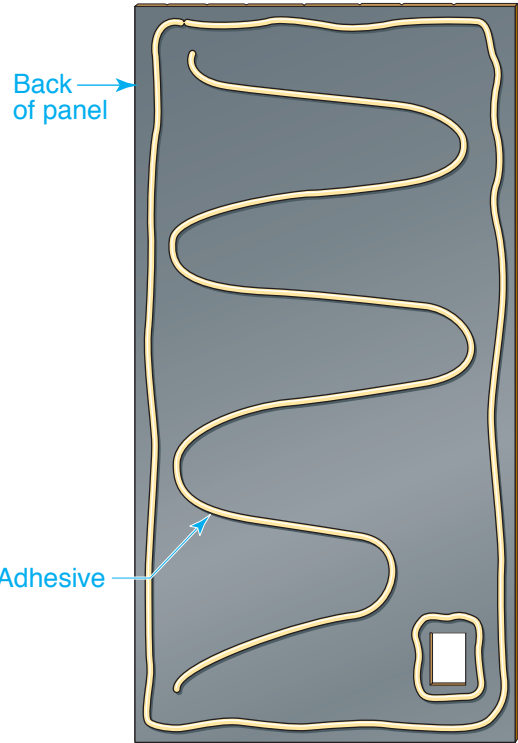

Figure 28-6 Adhesive Bonding

Nail Supplement Apply adhesive to the back of the panel. Keep it approximately 1" or more from the edges to avoid adhesive squeeze-out.

- of the panel and around any cutouts, as shown in **Figure 28-6**.
- Apply additional adhesive in a zigzag pattern in the middle.
- Position the panel and press it firmly against the adhesive.
- Place three or four finishing nails across the top of the panel to hold it in place.

Table 28-1: Nailing Recommendations for Interior Plywood Paneling

Plywood Thickness (inches)	Maximum Support Spacing (inches)	Nail Size (Use casing or finishing nails)	Nail Spacing (inches)	
			Panel Edges	Intermediate
$\frac{1}{4}$	16 ^(a)	4d	6	12
$\frac{5}{16}$	16 ^(b)	6d	6	12
$\frac{3}{8}$, $\frac{11}{32}$, $\frac{1}{2}$, $\frac{15}{32}$	24	6d	6	12
$\frac{5}{8}$, $\frac{19}{32}$, $\frac{3}{4}$	24	8d	6	12

^(a) Can be 20" if face grain of paneling is across supports.

^(b) Can be 24" if face grain of paneling is across supports.

- Place a padded block of wood against the panel and tap the block with a hammer or rubber mallet to achieve full-surface contact, as shown in **Figure 28-7**. Be sure to round over (ease) the corners and edges of the block so that they will not leave marks on the panel.
- If necessary, use small finishing nails to hold the panel flat until the adhesive reaches full strength.

Seams and Joints

Seams and joints between panels can be handled in a variety of ways. Some panels are designed with interlocking edges so that the joint needs no special treatment. Grooved panels are designed so that there are ½" width grooves at the vertical edges. When two panels are butted together, the joint nearly disappears. If desired, seams can be covered with wood or plastic molding that is color-matched to the paneling.

Inside Corners If panels fit very well in a corner, a butt joint is acceptable. However, to ensure a good fit, the edge of one panel may have to be scribed to fit against the other. Back-cutting the edge of the scribed panel improves the fit even more. Another way to handle the corner is to cut the edges of the intersecting panels so that they will fit into a preformed plastic corner, as shown in **Figure 28-8**. The corner should be installed before either panel is nailed into place.

Outside Corners If the paneling is unfinished and relatively thick, outside corners can sometimes be mitered. The sharp edge of the corner must be eased, however, to prevent damage over time. Some carpenters use biscuit joinery to strengthen the joint and ensure that the mitered edges meet uniformly (see Section 6.4). If panels meet at 90°, the joint can also be covered with a wood corner guard. Another approach is to use a prefinished outside corner molding as shown in **Figure 28-8B**. Instead of mitering the paneling, the edges can be cut square.

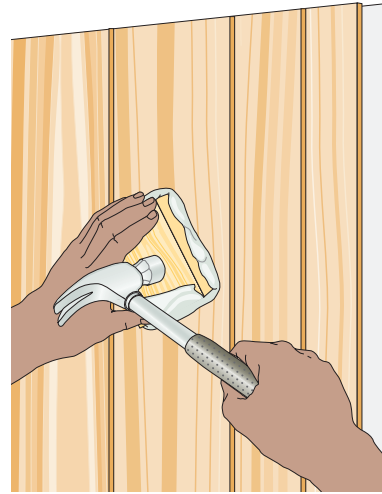

Figure 28-7 Bedding the Panel

Finish Protection Tap the panel with a hammer and a block to press it firmly into place. Put a cloth under the block to protect the panel finish.

Estimating

Determining the number of panels needed for a room is based on the square footage of the walls. The method is explained in the following Estimating and Planning feature.

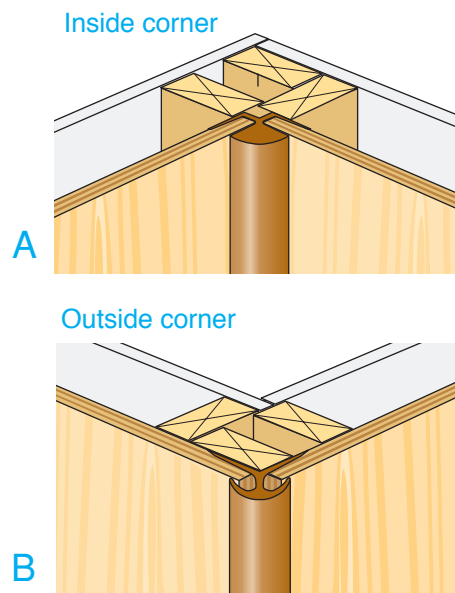

Figure 28-8 Prefinished Corner Molding

Inside and Outside Corner joints can be concealed with prefinished molding. The molding may have to be installed before the panels are placed.

Estimating and Planning



This estimating and planning exercise will prepare you for national competitive events with organizations such as SkillsUSA and the Home Builder's Institute.

Sheet Paneling

Estimate Perimeter

Step 1: Figure the perimeter of the room to be paneled by adding the lengths of the four walls together.

Step 2: Divide the perimeter by the width of the panel in inches.

$$18 + 18 + 15 + 15 = 66'$$

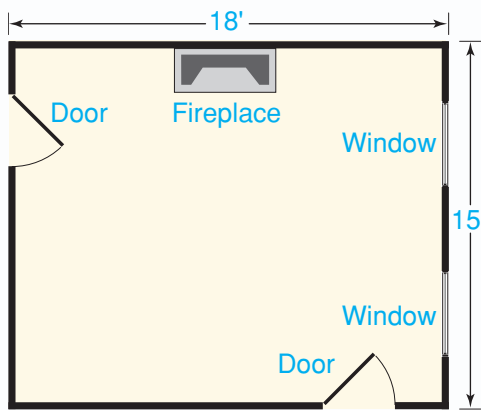

Step 3: Multiply this number by the waste allowance, which is usually 5 percent. Round up the result to the nearest whole number. This will be the number of panels you will need. In the floor plan that is shown here, 18 4×8 panels are required.

Step 4: If the ceiling height is more than 8', determine the additional height. For example, if the room shown in the first column has a 10' high ceiling, 2' of additional height are required. You would use 10' panels (if available) or cut four 2' pieces from an 8' panel. Since 18 panels are required to go around the room, 4½ (or, rounded up, 5) additional panels will be required ($18 \div 4 = 4\frac{1}{2}$), for a total of 23 panels.

Step 5: Deduct from the panel count for any large areas that will not be paneled, such as a fireplace. Do not deduct for windows and doors.

Estimating on the Job

Consult the floor plan in the first column. Figure the number of panels required if this room had a cathedral ceiling. Assume the following:

- The low walls are 8' in height.
- The ridge runs perpendicular to the fireplace wall.
- The roof over this room has a $\frac{1}{2}$ pitch (see Chapter 17 to review information about pitch).
- The paneling will be applied to all wall surfaces.
- There is no fireplace.

Section 28.1 Assessment

After You Read: Self-Check

1. Over what type of surface is paneling typically applied?
2. Why must drywall be taped and sanded before installing paneling?
3. Describe the process of scribing a panel for an inside corner.
4. How must paneling fit around electrical outlet boxes?

Academic Integration: English Language Arts

5. Create a "How To" Create a "how-to" explanation of how to cut out a shape in a panel to fit around an electrical outlet. List all the materials you will need. In addition, list the steps to follow in order. Make use of transitional words and phrases.

Go to glencoe.com for this book's OLC to check your answers.

Board Paneling

Board Paneling Basics

Where should paneling be conditioned?

Board paneling is a type of wall paneling made of solid wood. It comes in the form of individual boards that are applied to the wall one by one, as shown in **Figure 28-9**.

Only thoroughly seasoned wood should be used. The boards should not be too wide, or the gaps created by expansion and **contraction** will be excessive. A nominal 8" is the maximum width recommended in most parts of the United States. The boards are usually applied vertically, but they can be applied horizontally or diagonally.



Figure 28-9 Installing Board Paneling

Board by Board The interlocking edges of board paneling provide a gap-free joint. *What is board paneling made of?*

Types and Sizes

Many kinds of wood are made into boards for paneling, including Douglas fir and various species of pine. Solid oak or cherry is also used. A rustic or informal look can be obtained with knotty pine or recycled barnwood. A more formal look can be achieved with a hardwood such as cherry, walnut, or mahogany. Hardwood ranges from $\frac{3}{8}$ " to $\frac{3}{4}$ " thick and comes in lengths of 8' to 12' and longer. The edges of each board interlock with adjoining boards in either a lap joint or a tongue-and-groove (T&G) joint, shown in **Figure 28-10**. Square-edged boards can also be used, but then the joints are often covered with molding. A T&G edge lessens appearance problems caused by expansion and contraction. It also makes it easy to align the panels.

Storage and Conditioning

Always store paneling indoors. Stack the wood flat on the floor using stickers to separate the boards. Condition solid-wood paneling for seven days, if possible. It should be conditioned by being stored in the room that it will be installed in.



REGIONAL CONCERNS

Wood Availability The woods used for board and raised paneling may vary based on local availability. In the Northwest, for example, Douglas fir and Western red cedar are widely available. In northern California, redwood is sometimes used, particularly in period architecture. In the southern United States, cypress is more available than elsewhere. In New England, oak and white pine are popular. Each wood is generally less expensive within its home region.



Go to glencoe.com for this book's OLC for more information about regional concerns.

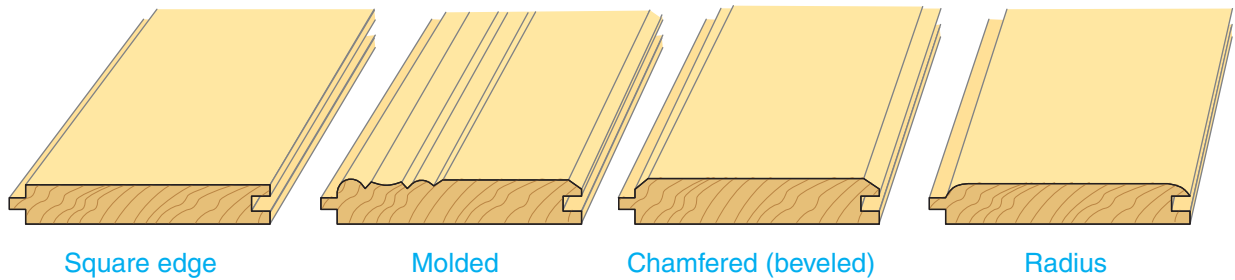

Figure 28-10 Board Patterns

Standard Patterns These are some tongue-and-groove paneling patterns. Most retail lumberyards carry two or three patterns in stock. *Why is it important that paneling boards are not too wide?*

Installing Board Paneling

What is blind nailing?

Solid-wood paneling can be installed on a wall vertically, horizontally, or at an angle. The orientation of the wood can have a dramatic effect on the look of a room.

Installing Boards Vertically

When paneling is to be attached directly to studs (if allowed by code), adequate blocking must be placed between the studs to provide nailing support, as shown in **Figure 28-11**. The blocking should not be more than 24" OC.

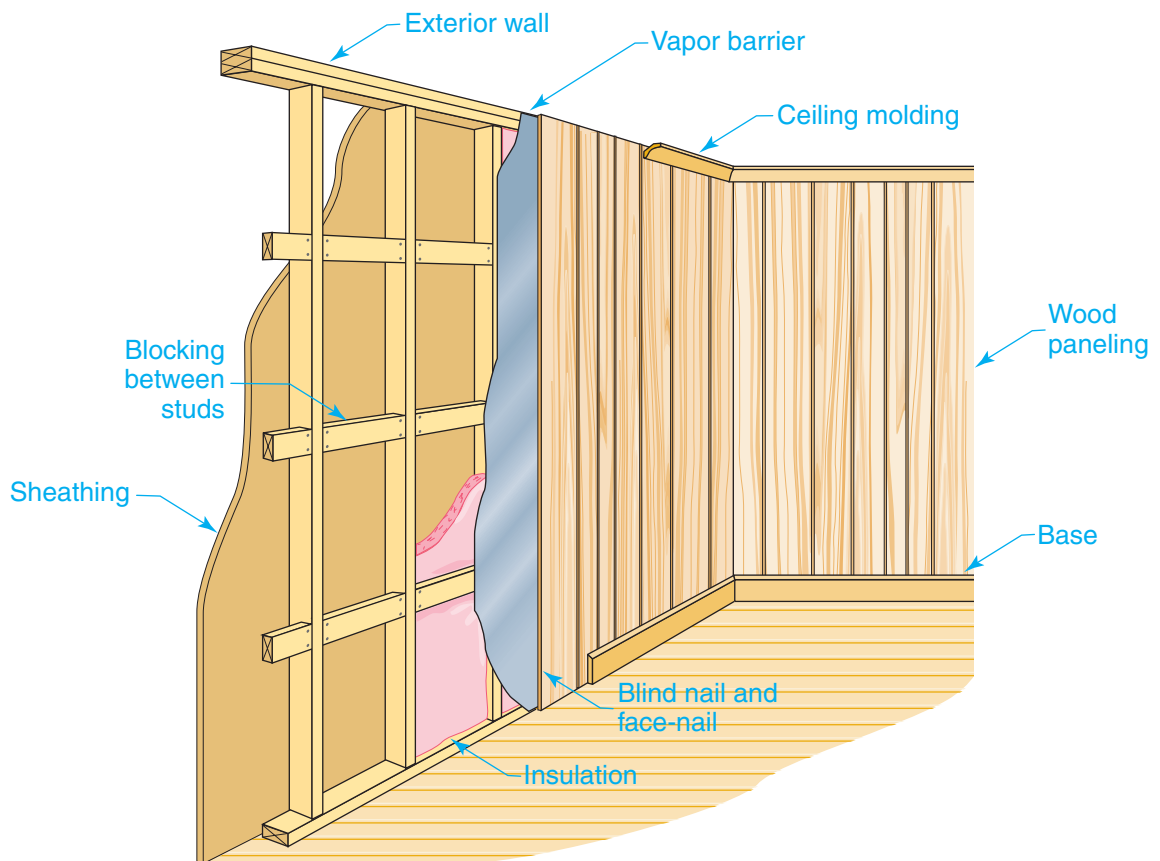

Figure 28-11 Blocking Details

Added Support Blocking provides a nailing surface for boards that are located between studs. This installation is on an exterior wall.

Once the paneling has been installed vertically, it can be trimmed with ceiling molding and baseboard in standard fashion.

Another approach is to butt the lower ends of the paneling into a 1×8 trim board, as shown in **Figure 28-12**. The ends of the vertical paneling will rest on the top edge of the 1×4 base. This detail is sometimes used when installing paneling over a drywall surface.

Positioning and Nailing

Once the horizontal blocking has been installed, the individual boards can be nailed in place. As with sheet paneling, the first board installed determines the layout of all following boards. If it is not plumb, this will make it difficult or impossible for any of the other boards to be plumb.

1. Starting at a corner, hold the first board in the corner and plumb it using a level. The grooved edge should be against the corner.
2. If the corner is not straight or plumb, you will have to scribe the board to fit. Undercut the edge about 5° to ensure a snug fit, as shown in **Figure 28-13**.

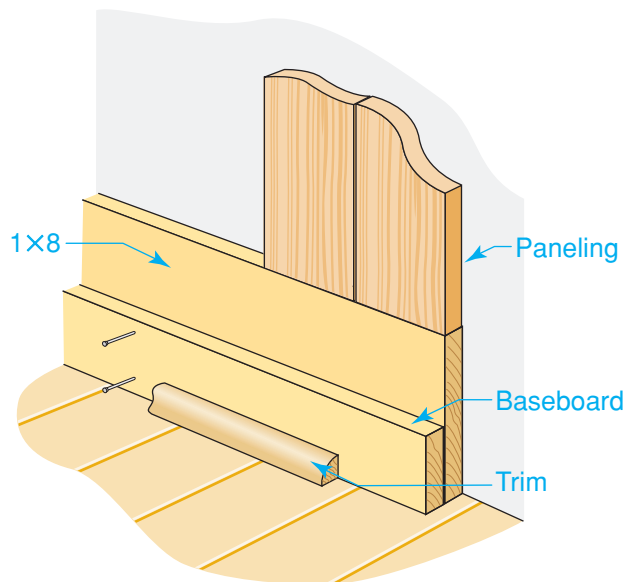

Figure 28-12 Baseboard Detail
Alternate Method This arrangement is possible when paneling is installed over drywall. The square-edged or molded baseboard is nailed to a furring strip.

Builder's Tip

MOISTURE CONTENT The moisture content of solid-wood paneling should be near the average it will reach in service—about 8 percent in most areas. However, in the dry southwestern United States, it should be about 6 percent. In the southern and coastal areas of the country, it should be about 11 percent. You can measure moisture content with a moisture meter.

3. Face nail the first board along the edge that is against the corner. Then blind nail the panel by driving 5d or 6d finishing nails at an angle through the tongue edge as shown in **Figure 28-14**. In **blind nailing**, the nails are driven at an angle through the tongue of the board

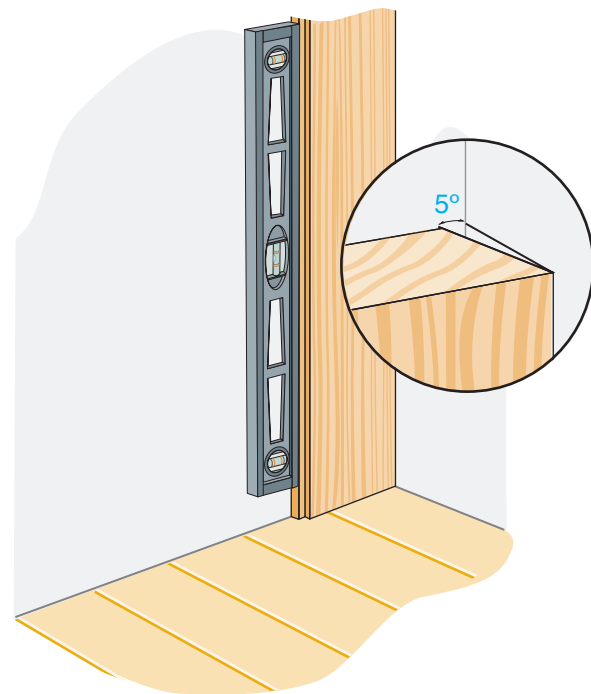

Figure 28-13 Setting the First Board
The First Board Is the Most Important The first board to be installed is scribed in a plumb position to the adjacent wall and undercut about 5° to provide a tight joint in the corner.

and into framing or furring strips. When the next board is installed, it will conceal the nail heads.

4. Continue to install boards, checking them for plumb frequently. A slightly out-of-plumb board can be repositioned and the slight difference in spacing will not be noticeable. When nearing the opposite corner, leave the second-to-last board loose.
5. When installing the last board on a wall, scribe the edge that is to fit into the corner and undercut it at an angle of about 5° . Then lift the edge of the preceding board slightly, position the last board, and snap both boards into place. Face nail the edge of the last board. (If the last board does not easily snap into place, cut off the bottom lip of its grooved edge, then press the board into place.)
6. Continue around the room in this fashion. Cut holes for outlets and other features as you encounter them. Where boards meet at outside corners, miter them or conceal the joint with molding.
7. Add ceiling and baseboard trim to complete the job.

Installing Boards Horizontally

Horizontal board paneling, while not as common as vertical paneling, has some advantages. Blocking is not required. Instead, boards can span the distance between studs. Because longer boards can be used, it is less time-consuming to apply.

Measure from the ceiling to the floor in several places to make sure all measurements are equal. If they are not equal, make sure the narrower board will be at the bottom.

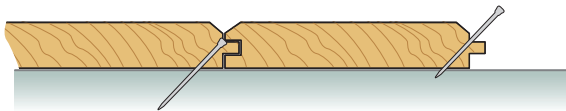

Figure 28-14 Blind Nailing
Invisible Nailing Blind nailing each paneling board conceals the nails.

Builder's Tip

RIGHTY OR LEFTY? The direction in which you move across a wall while installing vertical boards is a matter of personal preference. Right-handed people find it easier to start at the left side of a wall and work to the right. Left-handed people find the reverse to be easier.

1. Begin the paneling at the floor line, making certain that the first piece is level and the tongue edge is up.
2. Scribe the bottom edge to the floor to eliminate any gaps. The gaps can also be covered later with baseboard or trim.
3. Undercut the ends of each board about 5° to provide a tight joint at the inside corners of the wall.
4. Miter the boards at the outside corners as shown in **Figure 28-15** or trim them with molding.
5. Blind nail each board, checking periodically to make certain the boards remain level.

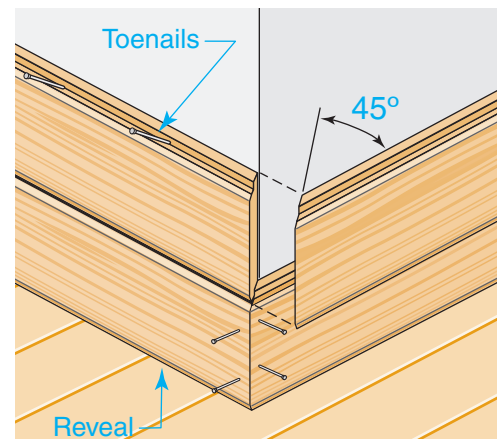
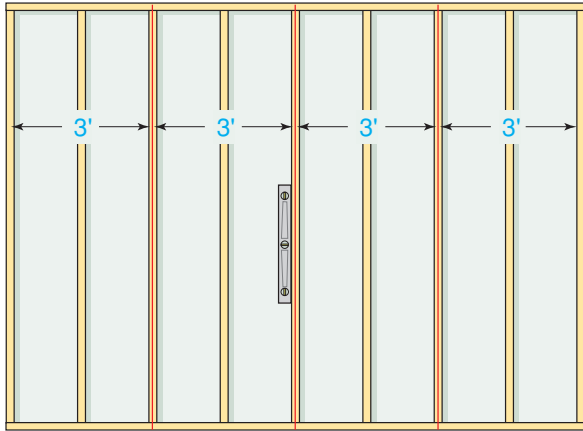

Figure 28-15 Mitered Corners
Lots of Fitting Wood paneling applied horizontally can be mitered at outside corners. In this installation, instead of a baseboard, a reveal is shown between the bottom board and the finished floor.

- If no molding is to be used at the ceiling, scribe and undercut the last panel edge at a 5° angle to ensure a snug fit.

Installing Boards at an Angle

Application of boards in the herringbone (chevron) pattern as shown in **Figure 28-16** is quite demanding. The boards can be nailed to existing studs, although studs may not be in the right place to support the ends. Instead, you may have to apply vertical furring strips so the space between studs is



A

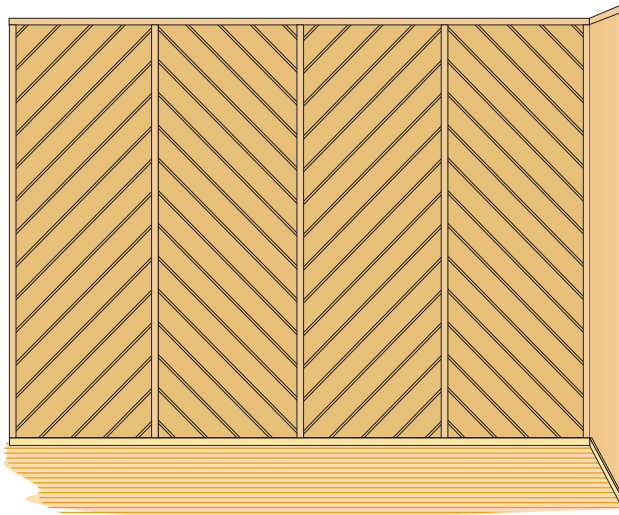

B

Figure 28-16 Furring Strip Placement

Careful Planning To install paneling in a herringbone style, furring strips should be installed (A) where they will support the ends of each board. To provide a symmetrical installation (B), locate furring strips accurately.

evenly divided. For example, if the wall is 12' long, you can place the strips 3' OC, as shown in **Figure 28-16B**. Make sure that each furring strip is plumb.

- Draw a plumb line at the center of every other furring strip. For a 12' wall, these lines should be 36" apart, or as close to that as possible.
- Cut two pieces of paneling in the shape of a 45° triangle, with the tongue on the long edge, as shown in **Figure 28-17**.
- Do not assume that the floor is level. Align the triangles with a vertical plumb line and to a level chalk line snapped across the wall at this point. The chalk line will serve to align this pair of starting triangles with other pairs. A molding strip will be applied later to cover the vertical joint.
- Cut the next pair of boards at a 45° angle and fit them into place on the next centerline. Continue to work across the wall along the other centerlines, building toward the top. A miter saw is extremely useful for repetitive angle cutting such as this.

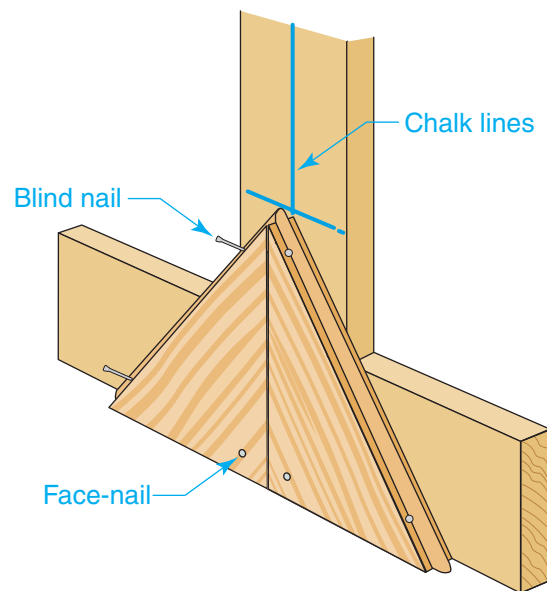

Figure 28-17 Starting the Boards

Small Pieces Cut the starting triangles and align them with the chalk lines. Then nail the triangles into place.

5. Blind nail the boards to each furring strip. Use the play in the tongue-and-groove joint to keep the boards aligned along the vertical joint. Check their horizontal alignment frequently.
6. After you have installed all the pieces, apply ceiling and baseboard molding. Then apply molding over the vertical joints in the paneling as in **Figure 28-18**. A cove or quarter-round may be used at the corners and a base shoe at the floor if necessary.

Raised Paneling and Wainscoting

Raised paneling is constructed much like raised-panel cabinet doors (see Chapter 27). The panels are made of solid wood, such as oak or cherry. Individual raised panels are held in place by a grid of stiles and rails

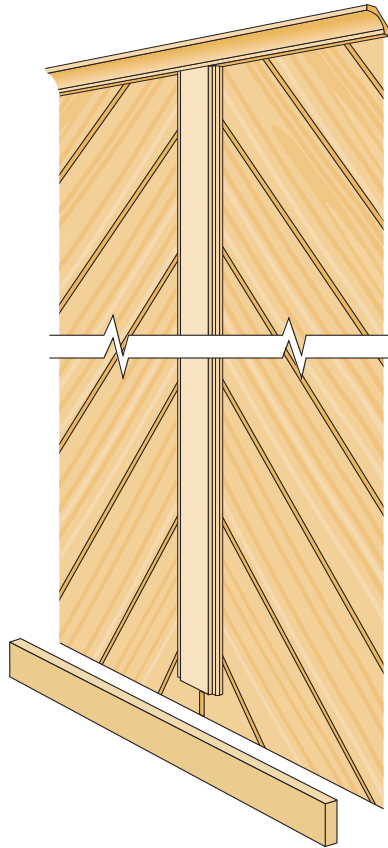

Figure 28-18 Molding
Final Detail Apply a molding strip at the vertical joint of the paneling. The molding should extend from the baseboard to the ceiling molding.

secured to the walls with nails or screws. Raised paneling is very expensive, so it is sometimes **simulated** with wood molding applied to sections of sheet paneling, as shown in **Figure 28-19**.

Board and sheet paneling is commonly applied from floor to ceiling, but a more formal look can be achieved by running it only on the lower portion of a wall. This is called wainscoting. A piece of wood molding runs along the top edge of wainscoting to conceal cut edges of the wood. The paneling shown in Figure 28-19 is an example of wainscoting.

Estimating

It is possible to estimate the number of paneling boards necessary by calculating the square footage of the walls, but two other methods result in more accurate figures. These methods are explained in the Estimating and Planning feature on page 822.



Figure 28-19 Wainscoting
Partial Paneling Wainscoting covers the lower portion of a wall. It is sometimes only 32" high and can be made using sheet paneling and molding, or with solid wood.



This estimating and planning exercise will prepare you for national competitive events with organizations such as SkillsUSA and the Home Builder's Institute.

Board Paneling

Estimating Material

Board paneling may be estimated by the board foot or by the lineal foot.

Board-Foot Method

Step 1: Figure the wall area to be covered by multiplying the perimeter times the ceiling height. Suppose a room has a perimeter of 66' and a ceiling height of 8'. Its wall area is 528 sq. ft.

$$66 \times 8 = 528$$

Step 2: Subtract the area for windows, doors, and fireplaces. Assuming that those in our example total 112 sq. ft., a total of 416 sq. ft. is to be covered by wood paneling.

$$528 - 112 = 416$$

Step 3: Multiply the total area to be covered by the area factor shown in **Table 28-2**. For example, suppose we are using tongue-and-groove 1×8 paneling. Its area factor is 1.16. If we multiply that by the 416 sq. ft. of wall space, we need 483 board feet of paneling.

$$416 \times 1.16 = 482.56, \text{ or } 483$$

Step 4: Add an allowance for trim and waste. For straight paneling, add 5 percent; for herringbone, add at least 10 percent. In our example, $483 \times 0.05 = 24.15$, or 24. Then $483 + 24 = 507$. The total amount of paneling required is 507 board feet.

Step 5: Multiply this figure by the cost per board foot to determine the total cost of the paneling.

Lineal-Foot Method

Step 1: Measure the height and length of the wall to be paneled.

Step 2: Determine the *face width* of the paneling. This is the portion of the board that will be visible when the paneling is in place. On a tongue-and-groove board, for example, this dimension does not include the tongue. The face width can be measured on a board. It is also given by the manufacturer or supplier in product specifications. For example, 1×6 boards have a face width of 5¼".

Step 3: Assume that a wall 14' long and 8' high will be paneled vertically. Convert the wall length to inches, for a total of 168".

$$14' \times 12 = 168''$$

Step 4: Divide this total by the face width. The answer will be 32.

$$168'' \div 5.25 = 32$$

This is the number of boards you will need.

Step 5: Multiply the number of boards by their length: $32 \times 8 = 256$. This is how many lineal feet of wood you will use. If the wall is 8'-6" high, however, you will have to order 10' boards and cut them down to size. You will still need 32 boards, but your lineal-foot total will be 320. For each board, the waste will be 18".

Step 6: Multiply the total lineal feet by the cost per foot to determine the total cost of the paneling.

Estimating on the Job

Using the board-foot method, estimate the amount of board paneling needed for a 15' × 20' room with 8' ceilings. Assume 126 sq. ft. will be used for doors and windows. The 1×6 panels will be placed tongue-and-groove in the herringbone pattern. How many board feet of paneling are needed?

Table 28-2: Estimating Coverage of Board Paneling

Paneling	Nominal Size	Width (inches)		Area Factor ^(a)
		Dress	Face	
Shiplap	1 × 6	5 ⁷ / ₁₆	4 ¹⁵ / ₁₆	1.22
	1 × 8	7 ¹ / ₈	6 ⁵ / ₈	1.21
Tongue-and-groove	1 × 4	3 ⁷ / ₁₆	3 ³ / ₁₆	1.26
	1 × 6	5 ⁷ / ₁₆	5 ³ / ₁₆	1.16
	1 × 8	7 ¹ / ₈	6 ⁷ / ₈	1.16
S4S	1 × 4	3 ¹ / ₂	3 ¹ / ₂	1.14
	1 × 6	5 ¹ / ₂	5 ¹ / ₂	1.09
	1 × 8	7 ¹ / ₄	7 ¹ / ₄	1.10

^(a) Allowance for trim and waste should be added.

Note: For most installations, an allowance of 5 percent will be adequate for trim and waste. Sometimes, rather than add 5 percent, the area of the doors and windows is not subtracted but is used as a trim and waste allowance.

Section 28.2 Assessment

After You Read: Self-Check

1. What is the recommended maximum nominal dimension for solid-wood paneling?
2. When solid-wood paneling is applied vertically directly to studs, what extra preparation is necessary?
3. What is blind nailing?
4. Is blocking required for horizontal paneling? Why or why not?

Academic Integration: Mathematics

5. **Estimating Lineal Feet** Using Table 28-2, estimate the amount in lineal feet of 1 × 4 tongue-and-groove board paneling that would be required for wainscoting on two walls of a room. One wall is 12 ft. long. The other wall is 14 ft. 6 in. long. Assume that the wainscoting will be 36 in. high and that there are no doors or windows in these walls.

Math Concept When solving measurement problems, convert quantities to the same unit of measure. When using a calculator, convert fractions and mixed numbers to decimals.

Step 1: Determine the combined length of the two walls that comprise the job. Convert to inches.

Step 2: Find the face width using Table 28-2. Convert to a decimal.

Step 3: Divide the length in inches by the face width. This is the number of boards you will need.

Step 4: Multiply the number of boards by their length in feet.

Step 5: Add a 5 percent allowance for trim and waste.

 Go to glencoe.com for this book's OLC to check your answers.

Review and Assessment

Section

28.1

Chapter Summary

Sheet paneling is the most common type of wall paneling and usually comes in 4×8 sheets. Drywall makes the best backing for sheet paneling. Panels can be applied with nails or adhesives. Molding is used to cover joints and seams.

Section

28.2

Board paneling is made of solid wood, and boards interlock with lap or tongue-and-groove joints. Raised paneling is made of solid wood. Paneling should be conditioned by placing it for at least 48 hours in the room in which it will be used. Board paneling may be installed vertically, horizontally, or at an angle. Blind nailing allows for nails placed through the tongue of one board to be hidden by the next. Edges are undercut to ensure a tight fit in corners.

Review Content Vocabulary and Academic Vocabulary

- Use each of these content vocabulary and academic vocabulary words in a sentence or diagram.

Content Vocabulary

- full-height paneling (p. 808)
- wainscoting (p. 808)
- sticker (p. 809)
- box extender (p. 811)
- board paneling (p. 816)
- blind nailing (p. 818)

Academic Vocabulary

- randomly (p. 810)
- contraction (p. 816)
- simulated (p. 821)

Speak Like a Pro

Technical Terms

- Work with a classmate to define the following terms used in the chapter: *sheet paneling* (p. 808), *conditioning* (p. 809), *mastic* (p. 809), *raised paneling* (p. 821), *face width* (p. 822).

Review Key Concepts

- Name the three basic types of paneling.
- Describe the ways full-height paneling and wainscoting are different.
- Tell how paneling should be stored and conditioned.
- Explain how sheet paneling is installed.
- Describe horizontal and vertical paneling.
- Create an estimate for the amount of sheet paneling required for your room.

Critical Thinking

- 9. Explain** Would you expect to find wood paneling made of Douglas fir or Western red cedar in a home in New England? Why or why not?

Academic and Workplace Applications

STEM Mathematics

- 10. Perimeter and Cost** A carpenter has been asked to submit a bid for remodeling a recreation room that is $16' \times 28'$ with 8' high walls. This bid includes removing the old paneling and installing $\frac{1}{4}'' \times 4' \times 8'$ oak paneling at \$10.19 per sheet of paneling plus 5.75% sales tax. How many sheets of paneling will be needed, and what is the cost of the paneling?

Math Concept To find the perimeter of a rectangle, multiply the length and the width by 2 and find their sum. To add a percentage of a number to itself, multiply the number by the percent plus 100.

- Step 1:** Find the perimeter of the room.
- Step 2:** To obtain the surface area, multiply the perimeter of the room by the height of the room.
- Step 3:** To figure 5% allowance for trim and waste, multiply the surface area by 105%.
- Step 4:** Divide the surface area by the area of one sheet of paneling. Round up to the next whole sheet.
- Step 5:** Determine the cost of the sheets and add 5.75% for sales tax.

STEM Science

- 11. Condensation** Condensation occurs when water vapor is changed into liquid form because it has been cooled. For example, during winter months, you might notice water droplets forming on windowpanes inside your home. Given this information, explain what might happen if you use paneling that has been

stored in an unheated garage during winter without first conditioning it.

Starting Hint Condensation occurs when water vapor in the air contacts a surface whose temperature is lower than the dew point, the temperature at which water condenses out of the air.

21st Century Skills

- 12. Career Skills: Connecting School to Work** List the connections between academic subjects you are taking and the work tasks in this chapter. For example, in what way would a carpenter benefit from studying geometry? How would a house remodeling construction manager benefit from studying a foreign language? Record your ideas in a bulleted summary or a one-page chart.

Standardized TEST Practice



True/False

Directions Read each of the following statements carefully. Mark each statement as either true or false by filling in T or F.

- (T) (F) 13.** The moisture content of solid-wood paneling should be near the average it will reach in service—about 8 percent in most areas.
- (T) (F) 14.** For most rooms, it is practical to start paneling from the center and then work around the room in both directions.
- (T) (F) 15.** It is possible to estimate the number of paneling boards necessary by calculating the square footage of the walls.

TEST-TAKING TIP

If you are allowed to use a book during a test, make sure that the book you are planning on bringing is authorized before the day of the test.

*These questions will help you practice for national certification assessment.

UNIT 6

Hands-On Math Project

Presenting a Professional Estimate

Your Project Assignment

An eco-conscious homeowner has asked for your bid to remodel a 200-square-foot kitchen. You will install new cabinetry, crown molding, and appliances in the new kitchen. You will create an estimate, then draw up and present your bid sheet to your potential client.

- **Predict** the total cost for the job.
-  **Build It Green Research** and price environmentally friendly materials and appliances.
- **Calculate** cost, overhead, profit, mark-up, and gross profit margin.
- **Draw** up a bid sheet, attaching a spreadsheet showing your calculations.
- **Interview** a local member of the National Association of the Remodeling Industry.
- **Create** a three- to five-minute presentation for the homeowner that explains your bid.

Applied Skills

Some skills you might use include:

- **Research** the costs involved in a construction project.
- **Identify** certified green materials and appliances.
- **Calculate** costs based on quantity and type of materials.
- **Check** cost-estimate predictions.



Math Standards

Problem Solving: Solve problems that arise in mathematics and in other contexts

Data Analysis and Probability: Formulate questions that can be addressed with data and collect, organize, and display relevant data to answer

Data Analysis and Probability: Develop and evaluate inferences and predictions that are based on data

NCTM National Council of Teachers of Mathematics

The Math Behind the Project

The traditional math skills for this project are estimation, data analysis, and measurement. Remember these key concepts:

Estimation

Accurate estimates rely on accurate calculations. If you offer a bid that is too low, you may lose money. If you offer a bid that is too high, you may not be offered the job. When estimating direct costs, make sure to include labor, materials, temporary power hook-ups, and insurance. Also include any necessary building permits.

Percentage

Profit, overhead, and mark-up are all calculated as percentages of cost. The typical overhead rate is 10%. Profits generally range from 5% to 20%, and mark-up runs from 5% to 50%. Mark-up is calculated on items that are purchased from a supplier and sold to the customer, such as a refrigerator or stove.

To calculate overhead, multiply your cost by your overhead rate. To calculate profit, add cost and overhead and multiply this total by the profit rate. Then figure your profit margin on the job by dividing the profit amount by the total amount of the job. Convert each percentage to a decimal before multiplying. For example, if the cost of the job is \$15,000, your overhead rate is 10%, and your profit rate is 20%, use the following steps:

1. Calculate overhead.	$\$15,000 \times .10 = \$1,500$
2. Add overhead to cost.	$\$1,500 + \$15,000 = \$16,500$
3. Calculate profit on cost and overhead.	$\$16,500 \times .20 = \$3,300$
4. Add profit to cost and overhead.	$\$3,300 + \$16,500 = \$19,800$
5. Calculate profit margin.	$\$3,300 \div \$19,800 = .167$

Convert profit margin to a percentage by moving the decimal point two places to the left. In this case, your profit margin is 16.7%.

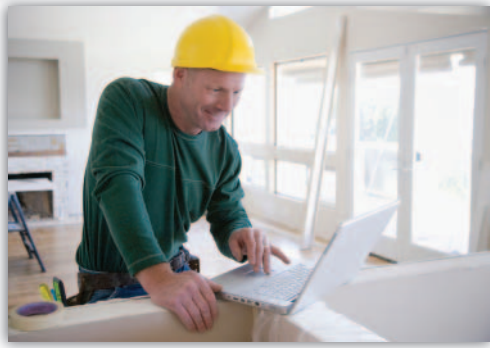

Project Steps

Step 1 Research

- Find a sample bid sheet for a construction or remodeling job.
- Consult the index of this book to find information on estimating costs for windows, cabinetry, drywall installation, painting, and flooring.
-  **Build It Green** Find and price green supplies and appliances, and products with certifications from programs such as Green Seal, the Forest Stewardship Council, and Energy Star.
- Predict the total cost of the job based on your research.

Step 2 Plan

- Choose the basic design for the new kitchen.
- Calculate the amount and price of materials, such as flooring, cabinetry, countertops, and paint.
- Choose the appliances you will use and your mark-up rate.

Step 3 Apply

- Itemize and calculate the costs for all materials you have selected.
- Calculate mark-up on the appliances.
- Estimate your direct costs for the job, including labor and materials.
- Calculate overhead, profit, and profit margin and create a spreadsheet showing all your calculations.
- Find a remodeling professional through the National Association of the Remodeling Industry. Ask him or her to review your calculations and offer suggestions and corrections based on local conditions.
- Create your bid sheet.
- Compare the final estimate on your bid sheet to your original prediction.

National Association of the Remodeling Industry

Mission: To advance and promote the remodeling industry's professionalism, product, and vital public purpose.

 Go to glencoe.com for this book's OLC for more information on this organization.

Step 4 Present

Prepare a presentation for the homeowner that shows and explains your bid sheet, demonstrates your research, and justifies your estimate.

PRESENTATION CHECKLIST

Did you remember to...

- ✓ Show your bid sheet and explain how to read it?
- ✓ Explain your choices for green materials and appliances?
- ✓ Show that your overhead, profit, and mark-up are fair?
- ✓ Demonstrate that your calculations are accurate?
- ✓ Show the thoroughness of your research and planning?

Step 5 Technical and Academic Evaluation

Assess yourself before and after your presentation.

1. Did you use an accepted format for your bid sheet?
2. Were labor, materials, and other costs itemized?
3. Were your costs based on solid research?
4. Did you select materials with environmental certifications?
5. Were your cost, overhead, and profit calculations accurate?

 Go to glencoe.com for this book's OLC for an evaluation rubric and Academic Assessment.



Construction.com
CONNECTION

 Go to glencoe.com for this book's OLC to read an article titled "Estimating: No Easy Task" to find out if four decades of digital evolution have changed estimating. Write a summary of the article.